

Mactenn

Mactenn

SYSTEMS LIMITED

Macawber Europe

INFORMATION SHEET

1-3-1

TYPE T SWITCH VALVE

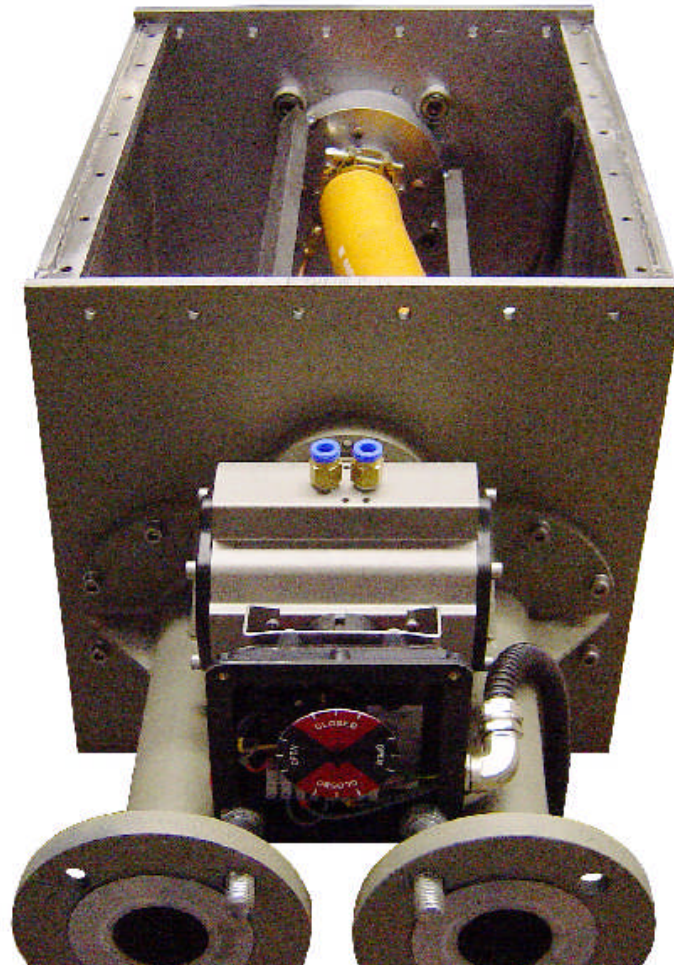

The **Type T Switch Valve** is used to form two branches in a conveying line handling cohesive or moist materials. It is self supporting in the conveying line and should be mounted vertically for best results. The valve action is self cleaning and does not leave any residual material between position changes.

The changeover action operates with a novel parallel motion which requires only a small movement to realign inlet and outlet parts for the new direction.

A pneumatic seal is incorporated into the wall of the internal pipe section which is automatically inflated when accepting a delivery of materials; to prevent the material entering the housing and the shaft bearings.

Mactenn

A Macawber Group Company

ADVANCED PNEUMATIC CONVEYING & INJECTION SYSTEMS
VALVES FOR ABRASIVE MATERIALS AND PRESSURE DUTY
BATCH MIXING AND INGREDIENT CONTROL
COMPLETE BULK MATERIAL SYSTEM DESIGN AND TURNKEY SUPPLY

Mactenn**Mactenn**

SYSTEMS LIMITED

Macawber Europe

INFORMATION SHEET

1-3-1

TYPE T SWITCH VALVE

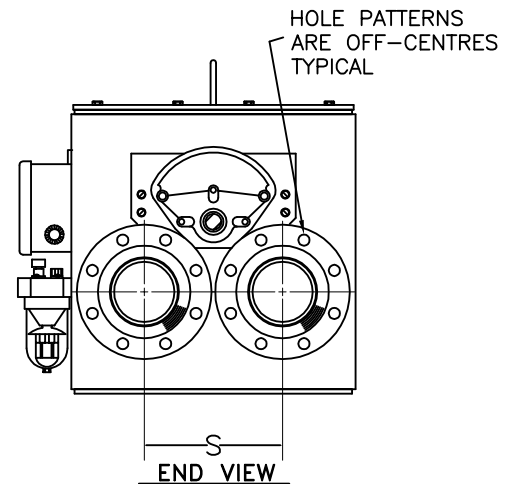
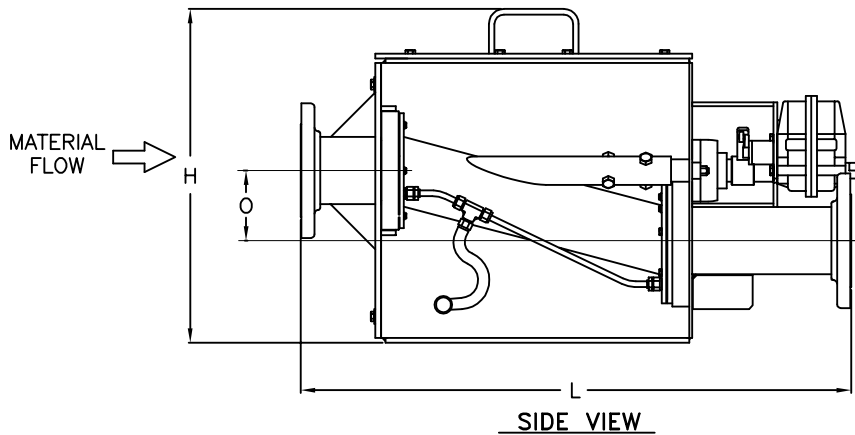
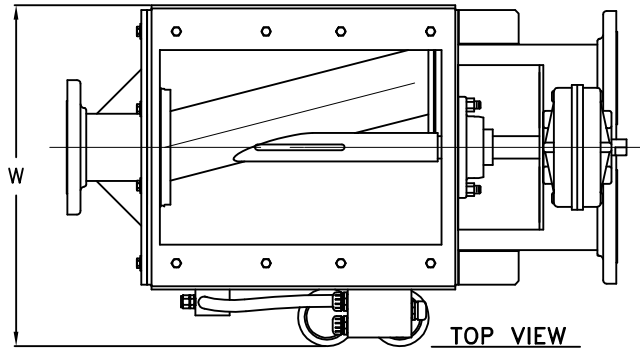

MODEL (PIPE SIZE)	DIMENSIONS (mm)					NET WT. (KG)
	W (WIDTH)	H (HEIGHT)	L (LENGTH)	S (PIPE SPACING)	O (OFFSET)	
50mm[2"]	386	378	624	157	79	95
80mm[3"]	482	473	781	197	102	141
100mm[4"]	581	568	937	232	121	189
125mm[5"]	645	632	1041	256	146	239
150mm[6"]	711	692	1143	289	146	290
200mm[8"]	870	851	1403	343	181	394
250mm[10"]	1032	1010	1664	419	213	501

INFORMATION NOT CERTIFIED FOR INSTALLATION PURPOSES

Mactenn**A Macawber Group Company**

ADVANCED PNEUMATIC CONVEYING & INJECTION SYSTEMS
 VALVES FOR ABRASIVE MATERIALS AND PRESSURE DUTY
 BATCH MIXING AND INGREDIENT CONTROL
 COMPLETE BULK MATERIAL SYSTEM DESIGN AND TURNKEY SUPPLY